

GENERAL

MATHESON FLOWMETERS COMBINE CONSTRUCTION AND PERFORMANCE FEATURES ESSENTIAL TO ACCURATE LOW FLOW MEASUREMENT. THIS INFORMATION IS INTENDED AS A GUIDE TO EFFICIENT USE; CAREFUL COMPLIANCE SHOULD RESULT IN LONG AND USEFUL SERVICE.

INSTALLATION

1. Immediately after unpacking, inspect unit for any damage incurred during shipment. Follow instructions on "Damage or Shortage" slip in packing container.
2. If a unit is supplied with an integral valve then ensure that the valve is open.
3. Check for free movement of float (s). Place meter horizontally on a flat surface with the ball float (s) at the maximum flow end of the tube (outlet). Incline this end of the meter approximately 10°. The float (s) should descend at a constant rate. As the float (s) approach the zero reference mark, they may slow down or hesitate. This is due to the close fit between the float and the tube. Foreign particles occasionally prevent the continuous motion of the float. Repeat the above operation several times. If the float sticks then see the "**CLEANING PROCEDURE**" shown below.
4. A 25 micron filter is recommended to be installed immediately upstream for meters where dirt can interfere with operation.

MOUNTING

1. The meter must be mounted in a vertical position with the inlet (lowest end of the scale reading) at the bottom. Attitude of more than 5° from the vertical will affect the accuracy of the meter. Panel mounted meters should be installed in position prior to connection to process piping. General good piping practice should be observed to prevent trapped fluid up or down stream of the meters. Connectors/adapters on the meter are supplied with wrench flats which must be held firmly when threading mating connections. Teflon tape should be used on pipe thread connections. NOTE: Care must be taken to avoid the shredding of Teflon tape which can foul meter operation.
2. Leak test final joints prior to operation. Leaks are often the cause of misleading flow indication.

OPERATION

1. **START-UP CAUTION.** Avoid sudden pressure surges. The impact of the float at the top of the tube can damage the meter if it is exposed directly to full line pressure. Avoid shock by closing the valve before start-up. Introduce pressure by slowly opening the valve.
2. **FLOW READING.** Flow indication is read at the center of the ball floats. Units of flow (SCCM, SCFH, etc.) are noted on the side of the tube. Tubes with millimeter, percent of maximum flow or linear scales require a calibration chart that corresponds to the metered fluid.

DISASSEMBLY (PM)

Units with an inlet valve: The meter is housed in the frame by means of a slotted plug at the top and the valve bonnet at the bottom.

- A. Remove the outlet adapter.
- B. Remove the valve.
- C. Remove the orifice inlet adapter.
- D. Remove the top plug with a flathead screwdriver.
- E. Remove the float stop spring with tweezers. (take note of the orientation of the spring)
- F. Slide the block out of the frame.
- G. Invert the meter to roll the float out of the block.

- C. Clean the float in the same manner.
- D. If the outside of the body needs cleaning then the use of a mild detergent is recommended.

REASSEMBLY (PM)

- A. Insert the block into the frame.
- B. Drop the float into the block.
- C. Insert the spring in the original orientation.
- D. Screw the top plug into the meter until it is flush with the frame.
- E. Assemble the inlet orifice adapter about 1/2 turn from the valve bushing making sure the O-ring goes in.
- F. Use two wrenches to screw the valve into the meter.
- G. Attach the outlet adapter.
- H. Check the meter for leaks.

DISASSEMBLY (PG)

Units with an inlet valve: The meter is housed in the frame by means of a slotted plug at the top and the valve bonnet at the bottom.

- A. Remove the outlet adapter.
- B. Remove the valve.
- C. Remove the orifice inlet adapter.
- D. Remove the top plug with a flathead screwdriver.
- E. Remove the float stop spring with tweezers. (take note of the orientation of the spring)
- F. Slide the block out of the frame.
- G. Remove the tube from the block.
- H. Remove the O-ring from the block.
- I. Remove the top extrusion from the tube
- J. Tilt the tube to roll the float out.
- K. Remove the bottom extrusion.

REASSEMBLY (PG)

- A. Insert the bottom extrusion in the tube.
- A. Drop the float into the block.
- B. Insert the top extrusion in the tube.
- C. Insert the tube with the scale in the front into the block.
- D. Insert the block into the frame.
- E. Insert the spring in the original orientation.
- F. Insert a pencil head eraser in the outlet of the meter to hold the tube while screwing the top plug into the meter until it is flush with the frame.
- G. Assemble the inlet orifice adapter about 1/2 turn from the valve bushing making sure the O-ring goes in.
- H. Use two wrenches to screw the valve into the meter.
- I. Attach the outlet adapter.
- J. Check the meter for leaks.

CLEANING PROCEDURE (Please notify the factory if cleaning for oxygen service is required)

- A. Flush the inside of the tube with solvent (without wax or inhibitors, i.e. glycols). Isopropyl alcohol 90% is recommended. All parts should be ultrasonically cleaned if possible
- B. Blow dry.

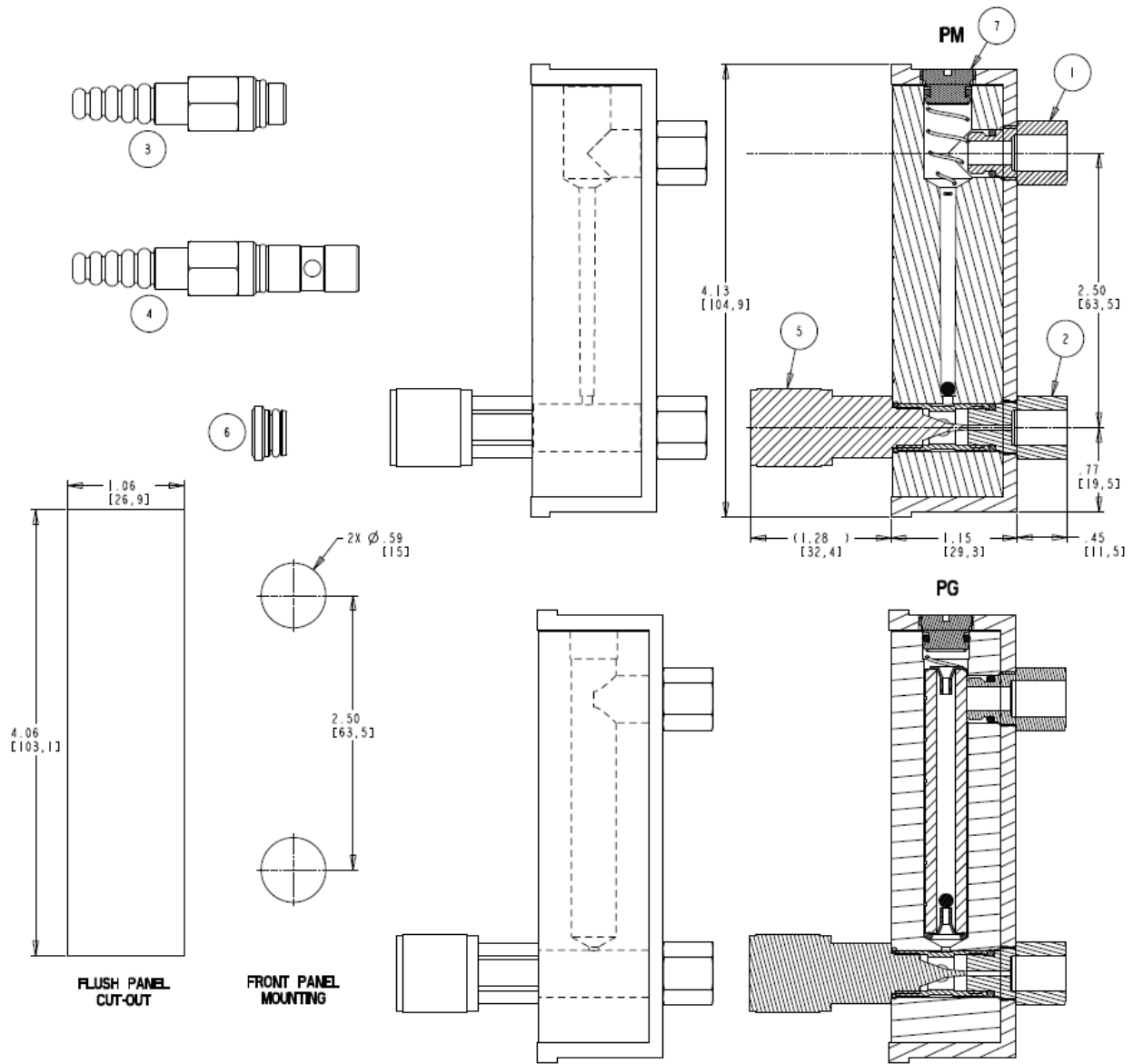

#	Qty	Part Number	Description
1	1	SEQ ABT0101BO	Adapter, 1/8"FNPT – Outlet, Brass/Buna
	1	SEQ ABT0101SA	Adapter, 1/8"FNPT – Outlet, SS/Viton
2	1	SEQ ABT0102BO	Adapter, 1/8"FNPT – Valve End, Brass/Buna
	1	SEQ ABT0102SA	Adapter, 1/8"FNPT – Valve End, SS/Viton
3	1	SEQ AHT0101BO	Adapter, Hose Barb – Outlet, Brass/Buna
	1	SEQ AHT0101SA	Adapter, Hose Barb – Outlet, SS/Viton
4	1	SEQ AHT0102BO	Adapter, Hose Barb – Valve End, Brass/Buna
	1	SEQ AHT0102SA	Adapter, Hose Barb – Valve End, SS/Viton
5	1	SEQ VLV0201BO	Valve, PM/PG, Brass/Buna
	1	SEQ VLV0201SA	Valve, PM/PG, SS/Viton
6	1	SEQ PLU0102BA	Valve Plug, SS/Buna
7	1	SEQ PLU0103BA	End Plug, PM/PG, Brass/Buna
	1	SEQ PLU0103SA	End Plug, PM/PG, SS/Viton