

Vertical Flow Sensors



FV4 Series

- Senses increasing or decreasing flow in gas systems
- Actuates an electrical switch at a predetermined flow range
- Welded 316L SS construction
- Working pressures up to 5000 psig (344 bar)

Materials of Construction

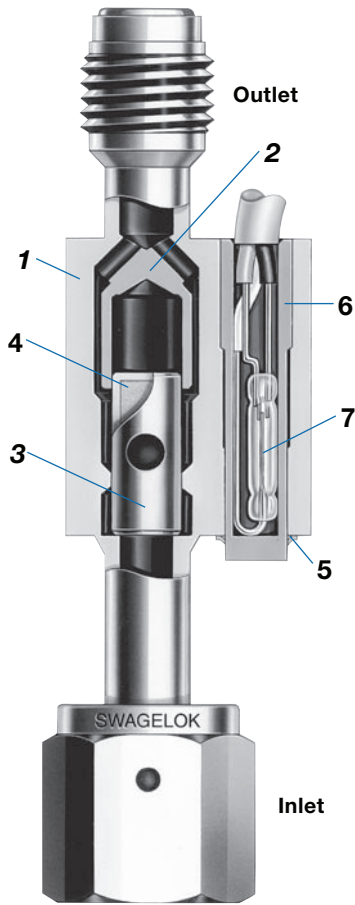

Component	Material Grade/ ASTM Specification
1 Body	<i>316L SS/A479</i>
2 Float guide	
3 Float	
4 Magnet	Samarium cobalt
5 Retaining ring	300 stainless steel
6 Capsule	Plastic
7 Reed switch	Mixed, including epoxy sealant

Wetted components listed in *italics*.

Reed Switch	
Type	
Single-pole, double-throw, 3-wire/2-position	
Contact Rating	
Power	3 W max
Voltage	100 V (dc) max
Switching current	250 mA max
Initial contact resistance	0.200 Ω max
Cable Leads	
Wire	22 AWG, 7/30, 80°C, 300 V
Jacket	PVC
Length	36 in. (91.4 cm)
White	Common
Red	Normally closed
Black	Normally open

Features

- Models can be selected to sense either increasing flow or decreasing flow.
- Snap-action float provides positive actuation.
- All-welded construction ensures fluid containment.
- High-strength, permanent magnet and 316L SS materials enhance durability.
- Replaceable switch assembly outside flow path eases maintenance.

Operation

The Swagelok FV4 series flow sensor contains a float with a calibrated orifice that moves up or down in the float guide as flow increases or decreases. A magnet encased in the float above the orifice alternates electrical continuity between the **black** and the **red** leads of the adjacent reed switch.

Increasing Flow—Float Down

During normal flow, the float is *down* at the bottom of the sensor body and electrical continuity is through the **red** lead of the switch.

When flow **increases** to within the actuation range:

- differential pressure across the float orifice snaps the float *up* to the top of the float guide
- continuity switches to the **black** lead.

As flow returns to normal:

- the float drops *down* to the bottom of the sensor body
- the magnet draws the common reed to the **red** lead
- continuity switches to the **red** lead.

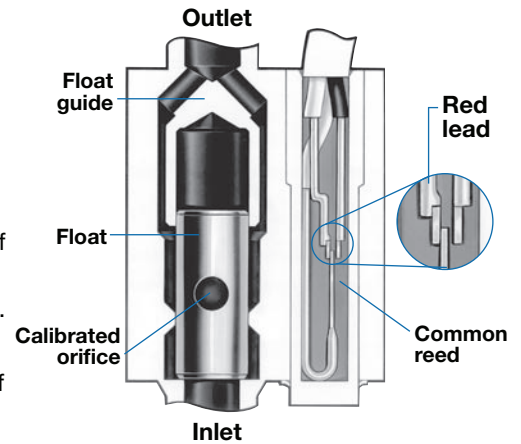

Decreasing Flow—Float Up

During normal flow, the float is *up* at the top of the float guide and electrical continuity is through the **black** lead of the switch.

When flow **decreases** below the actuation range:

- the float drops *down* to the bottom of the sensor body
- the magnet draws the common reed to the **red** lead
- continuity switches to the **red** lead.

As flow returns to normal:

- differential pressure across the float orifice snaps the float *up* to the top of the float guide
- continuity switches to the **black** lead.

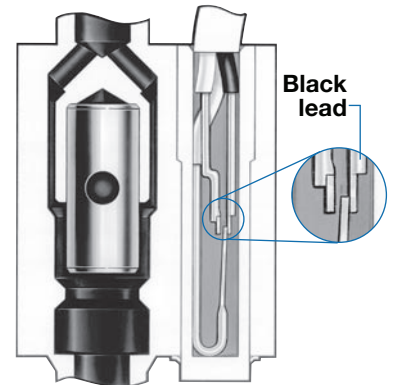

Technical Data

Pressure-Temperature Ratings

Material	316L SS
Temperature °F (°C)	Working Pressure psig (bar)
-40 (-40) to 100 (37)	5000 (344)
175 (79)	4415 (304)

Flow Coefficient—0.5

Flow, Sizing, and Selection

Sizing to Sense Increasing Flow

Size the float to actuate the switch after flow **exceeds** the maximum rate.

Increasing Flow

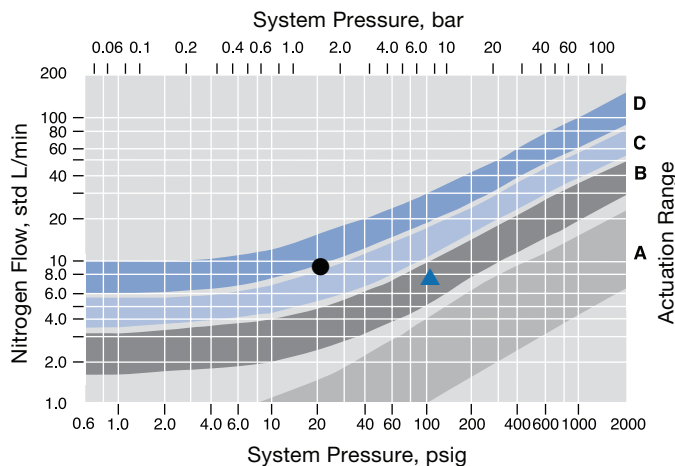

Example:

Nitrogen process gas

8 std L/min maximum system flow rate

100 psig (6.8 bar) system pressure

- Using the **Increasing Flow** graph, find the intersection of the system pressure (100 psig [6.8 bar]) and the maximum system flow rate (8 std L/min). ▲
- Locate the range directly **above** the intersection point (Range **C**).
- Insert **C** into the sensor ordering number.

Example: 6L-FV4C-S4

Cleaning and Packaging

All FV4 series flow sensors are processed in accordance with *Swagelok Special Cleaning and Packaging (SC-11)*, MS-06-63, to ensure compliance with product cleanliness requirements stated in ASTM G93 Level C.

Testing

Every FV4 series flow sensor is tested for proper operation and is helium leak tested at the envelope to a maximum leak rate of 4×10^{-9} std cm³/s.

Installation

⚠ **The FV4 series flow sensor must be installed in a vertical orientation with the arrow pointing up.**

Sizing to Sense Decreasing Flow

Size the float to actuate the switch before flow **drops below** the minimum rate.

Decreasing Flow

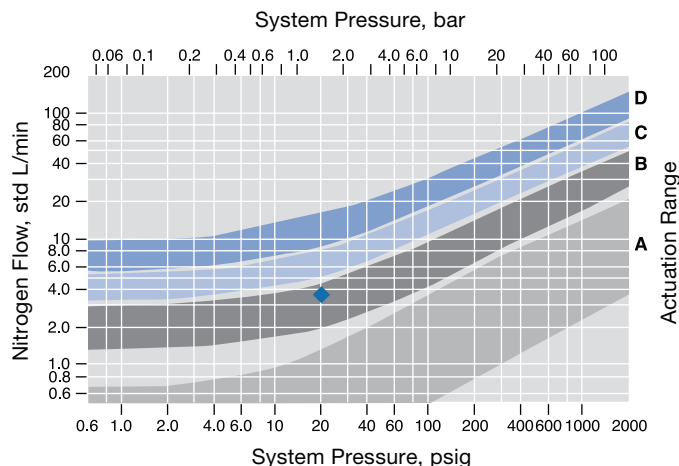

Example:

Nitrogen process gas

10 std L/min normal system flow rate

4 std L/min minimum system flow rate

20 psig (1.3 bar) system pressure

- Using the **Decreasing Flow** graph, find the intersection of the system pressure (20 psig [1.3 bar]) and the minimum system flow rate (4 std L/min). ◆
- Locate the range directly **above** the intersection point (Range **C**).
- Using the **Increasing Flow** graph, find the intersection of the system pressure (20 psig [1.3 bar]) and the normal system flow rate (10 std L/min). ●
Verify that the range identified in Step 2 (Range **C**) is below the intersection point.
- Insert **C** into the sensor ordering number.

Example: 6L-FV4C-T4A

Sizing for Other Gases

To size the float for gases other than **nitrogen**, multiply the process gas flow rate by the density correction factor (F_d) to obtain equivalent nitrogen flow rates.

$$F_d = \sqrt{\frac{MW_{\text{process}}}{28}}$$

Proceed with sizing as described above.

MW_{process} = molecular weight of process gas.

Ordering Information and Dimensions

Dimensions, in inches and (millimeters), are for reference only and are subject to change.

For a complete ordering number, insert the actuation range designator **A, B, C,** or **D** (see graphs on page 3) into the basic ordering number.

Example: 6L-FV4A-S4

End Connections		Basic Ordering Number	Dimensions in. (mm)	
Type	Size		H	J
Swagelok tube fittings	1/4 in.	6L-FV4__-S4	3.68 (93.4)	9/16 (14)
	6 mm	6L-FV4__-S6M		
Male VCR® fittings	1/4 in.	6L-FV4__-VR4	3.10 (78.7)	—
Female to male VCR fitting	1/4 in.	6L-FV4__-FR4-VR4		3/4
Tube extensions	1/4 × 0.035 in.	6L-FV4__-T4A	3.19 (81.0)	—
	6 × 1 mm	6L-FV4__-T6MA		

Dimensions shown with Swagelok tube fitting nuts finger-tight.

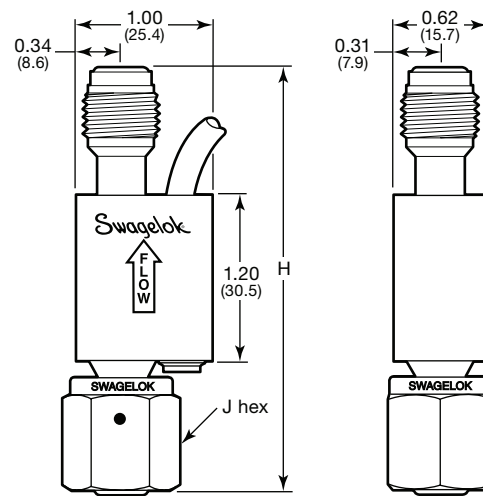

Accessories

Reed Switch Kit

Replacement switch kit includes switch assembly, retaining ring, assembly tool, and assembly instructions.

Ordering number: **MS-SRK-FV4**

Oxygen Service Hazards

For more information about hazards and risks of oxygen-enriched systems, see the Swagelok *Oxygen System Safety* technical report, MS-06-13.

Safe Product Selection

When selecting a product, the total system design must be considered to ensure safe, trouble-free performance. Function, material compatibility, adequate ratings, proper installation, operation, and maintenance are the responsibilities of the system designer and user.

Caution: Do not mix or interchange parts with those of other manufacturers.

Warranty Information

Swagelok products are backed by The Swagelok Limited Lifetime Warranty. For a copy, visit swagelok.com or contact your authorized Swagelok representative.