

REVISIONS					
SH-ZONE	REV	DESCRIPTION	ECO NO.	BY/DATE	APVD/DATE
-	A	RELEASED FOR PRODUCTION	-	DL-12/22/20	WS-1/8/21
B1	B	REVISED CLEANING SPECIFICATION	-	DL-4/6/23	WS-4/6/23
B2	C	ADDED TOP VIEW PORT LAYOUT	-	DL-4/24/23	WS-4/24/23

MODEL NO.	MAX DELIVERY PRESSURE	DELIVERY PRESSURE GAUGE
3811A	15 PSI	30" VAC-0-30 PSI
3813A	50 PSI	30" VAC-0-100 PSI
3810A	125 PSI	30" VAC-0-200 PSI
3816A	250 PSI	0-400 PSI
3818A	500 PSI	0-1000 PSI

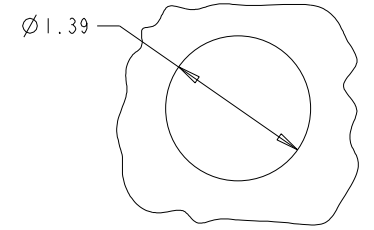

PANEL CUT-OUT

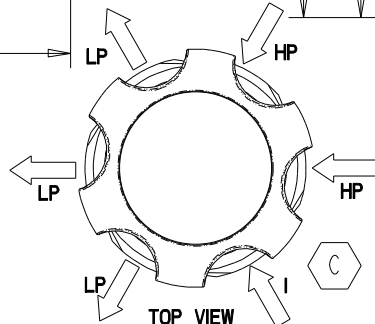
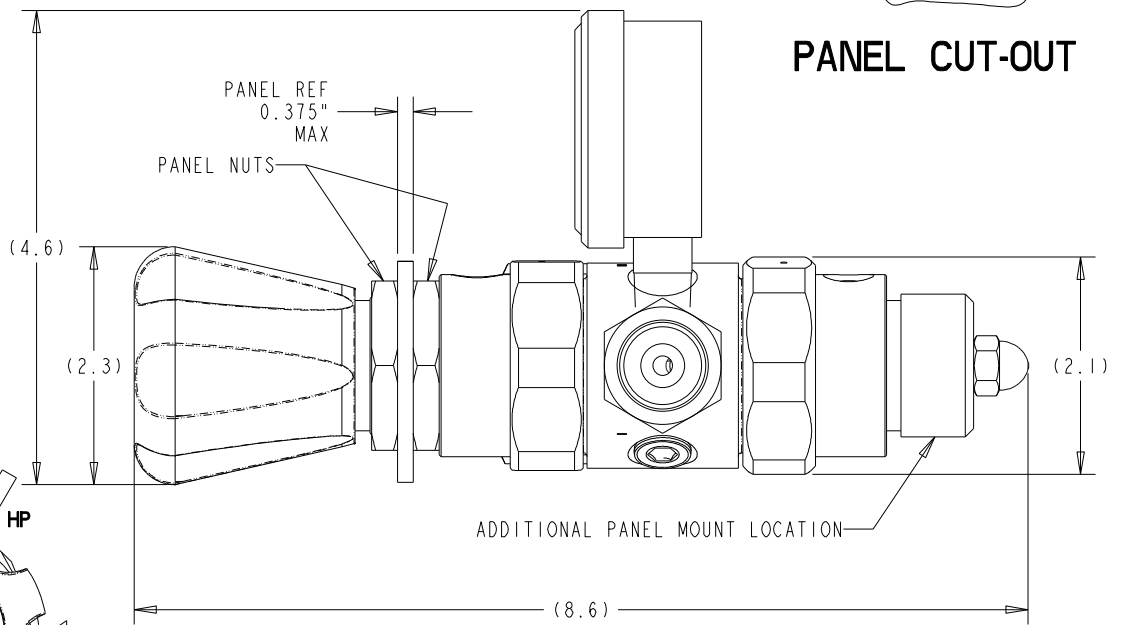
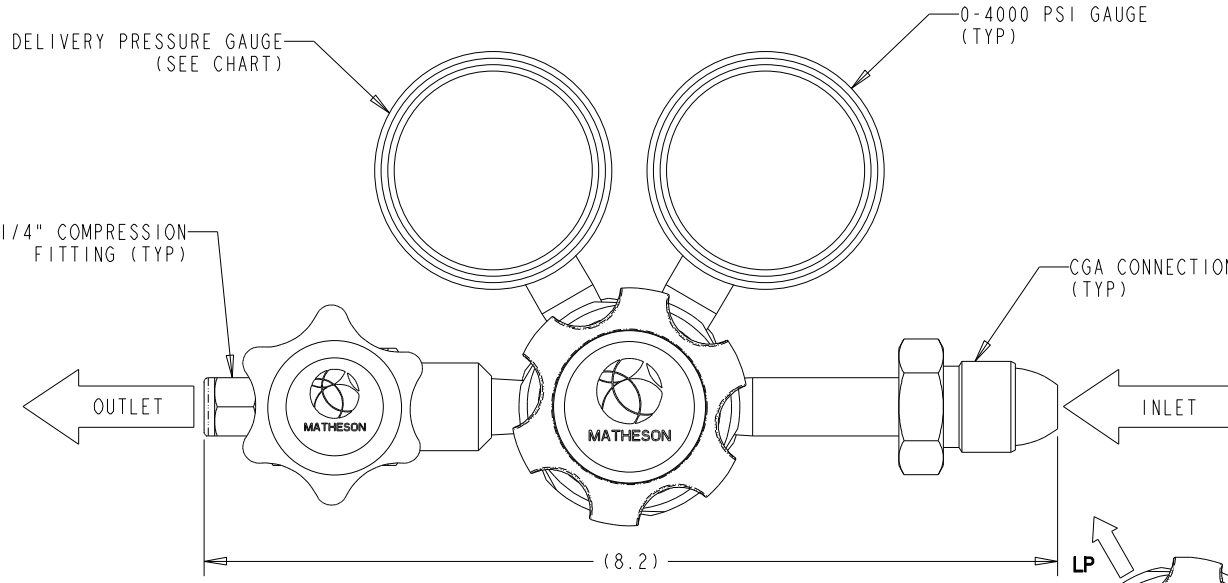

MATERIALS	
REGULATOR BODY	316L STAINLESS STEEL BARSTOCK
REGULATOR BONNETS	CHROME PLATED BRASS BARSTOCK
REGULATOR DIAPHRAGMS	316L STAINLESS STEEL
REGULATOR SEAT (1st STAGE)	TEFLON
REGULATOR SEAT (2nd STAGE)	TEFLON
REGULATOR SEALS	METAL TO METAL
INLET FILTER	316L STAINLESS STEEL
VALVE BODY	316L STAINLESS STEEL
VALVE DIAPHRAGM	316L STAINLESS STEEL
VALVE SEAT	PCTFE

SPECIFICATIONS	
MAXIMUM INLET PRESSURE	3000 PSI (20,700 kPa)
REGULATOR FLOW CAPACITY (Cv)	0.06
OPERATING TEMPERATURE	-40°F TO 140°F (-40°C TO 60°C)
PORTING (REGULATOR BODY)	1/4" NPT FEMALE
PORTING CONFIGURATION	2 HIGH, 3 LOW, 1 INTERSTAGE
INLET FILTER	10 MICRON - SINTERED
BONNET THREADING	1-3/8"-12
BONNET VENT HOLE	1/8" NPT
VALVE FLOW CAPACITY (Cv)	0.13
LEAK TEST	1 x 10 ⁻⁵ SCCM-HE
CLEANING	CGA G 4.1
PRESSURE RATING	PER ANSI/ASME B31.3
TYP MAX FLOW (100 PSI DEL. PRESS.)	7 SCFM-N2 (200 SLPM)
CONFORMS TO CGA E-4 STANDARD FOR GAS PRESSURE REGULATORS	

PROPRIETARY STATEMENT THIS DOCUMENT CONTAINS INFORMATION PROPRIETARY TO MATHESON TRI-GAS, INC. AND SHALL NOT BE REPRODUCED OR DISCLOSED TO THIRD PARTIES WITHOUT PRIOR WRITTEN CONSENT FROM MATHESON TRI-GAS.

TOLERANCES

INCH	METRIC
X ± .1	X ± .8
.X ± .03	.X ± .3
.XX ± .01	.XX ± .13
.XXX ± .005	
63 ✓	1.6 ✓
ANGLES ± 1/2°	

MATERIAL:

FINISH:

THIRD ANGLE PROJECTION

DO NOT SCALE DRAWING

APPROVALS

DRAWN BY:	DATE:
DL	12/22/20
CHECKED BY:	DATE:
WS	1/8/21
ENGINEER:	DATE:
WS	1/8/21

MATHESON
ask...The Gas Professionals™

GAS EQUIPMENT TECHNOLOGY GROUP, MONTGOMERYVILLE, PA 18936

TITLE:
**OUTLINE DRAWING
3810A SERIES REGULATOR,
DUAL STAGE, SS**

SIZE: **C**

DWG. NO.: **3810A-OL**

REV: **C**

CREO SCALE: NTS SHEET 1 OF 1