

4

3

2

1

REF ONLY FOR PDM USE ONLY	DWG NO. 3530A-OL-	MODEL NO. M3539A-580-
------------------------------	----------------------	--------------------------

REVISIONS					
SH-ZONE	REV	DESCRIPTION	ECO NO.	BY/DATE	APVD/DATE
-	A	RELEASED FOR PRODUCTION	-	DL-12/18/20	WS-12/21/20

MODEL NO.	MAX DELIVERY PRESSURE	DELIVERY PRESSURE GAUGE
3531A	15 PSI	30" VAC-0-30 PSI
3537A	50 PSI	30" VAC-0-100 PSI
3539A	125 PSI	30" VAC-0-200 PSI
3536A	250 PSI	0-400 PSI
3538A	500 PSI	0-1000 PSI

D

D

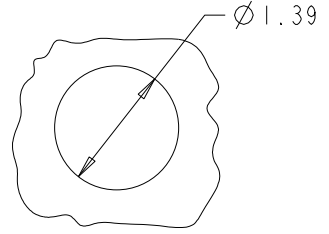

PANEL CUT-OUT

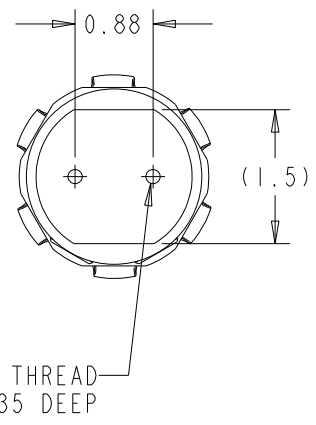
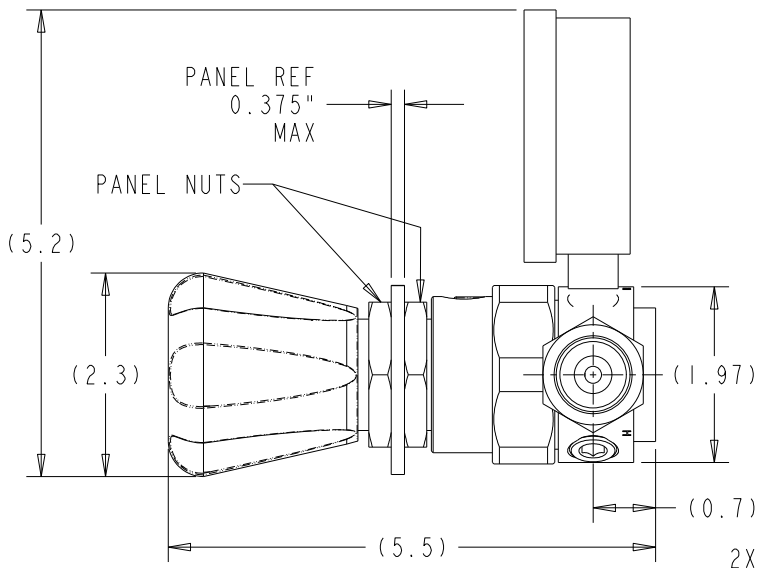
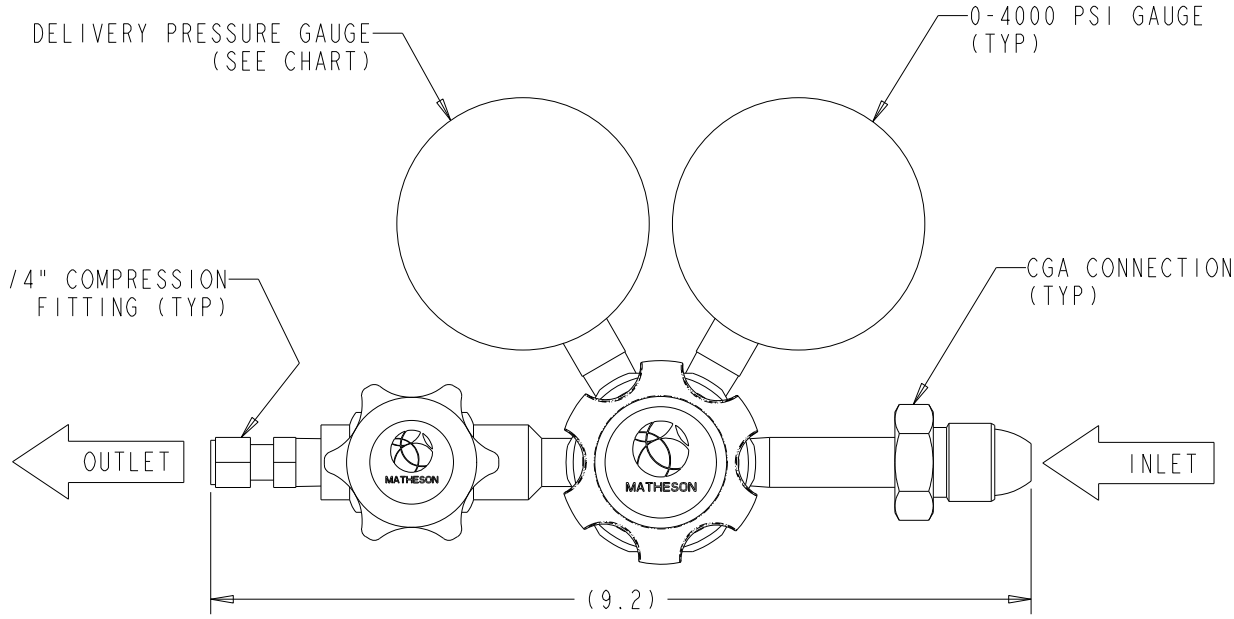

C

C

B

B

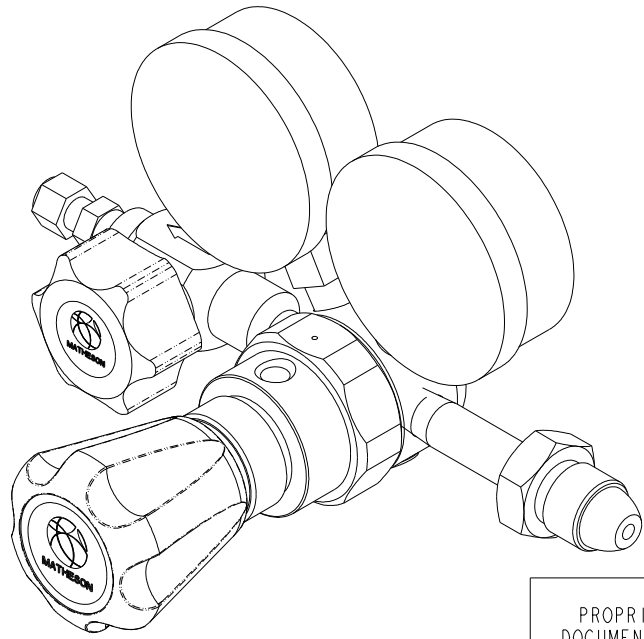

MATERIALS	
REGULATOR BODY	NICKEL PLATED BRASS BARSTOCK
REGULATOR BONNET	CHROME PLATED BRASS BARSTOCK
REGULATOR DIAPHRAGM	316L STAINLESS STEEL
REGULATOR SEAT	TEFLON
REGULATOR SEALS	METAL TO METAL
INLET FILTER	NICKEL PLATED BRONZE
VALVE BODY	NICKEL PLATED BRONZE
VALVE DIAPHRAGM	316L STAINLESS STEEL
VALVE SEAT	PCTFE

SPECIFICATIONS	
MAXIMUM INLET PRESSURE	3000 PSI (20,700 kPa)
REGULATOR FLOW CAPACITY (Cv)	0.08
OPERATING TEMPERATURE	-40°F TO 140°F (-40°C TO 60°C)
PORTING (REGULATOR BODY)	1/4" NPT FEMALE
PORTING CONFIGURATION	3 HIGH, 3 LOW
INLET FILTER	10 MICRON - SINTERED
BONNET THREADING	1-3/8"-12
BONNET VENT HOLE	1/8" NPT
VALVE FLOW CAPACITY (Cv)	0.13
LEAK TEST	1 x 10 <sup>-5</sup> SCCM-HE
CLEANING	CGA G 4.1 & ASTM G93 (INTER LEVEL)
PRESSURE RATING	PER ANSI/ASME B31.3
TYP MAX FLOW (100 PSI DEL. PRESS.)	8 SCFM-N <sub>2</sub> (230 SLPM)
CONFORMS TO CGA E-4 STANDARD FOR GAS PRESSURE REGULATORS	

A

A

PROPRIETARY STATEMENT THIS DOCUMENT CONTAINS INFORMATION PROPRIETARY TO MATHESON TRI-GAS, INC. AND SHALL NOT BE REPRODUCED OR DISCLOSED TO THIRD PARTIES WITHOUT PRIOR WRITTEN CONSENT FROM MATHESON TRI-GAS.	<b>TOLERANCES</b>		MATERIAL:  FINISH:  THIRD ANGLE PROJECTION DO NOT SCALE DRAWING	<b>APPROVALS</b>		<b>MATHESON</b> <i>ask...The Gas Professionals™</i> GAS EQUIPMENT TECHNOLOGY GROUP, MONTGOMERYVILLE, PA 18936  <b>TITLE:</b> <b>OUTLINE DRAWING</b> <b>MODEL 3530A SERIES,</b> <b>SINGLE STAGE REGULATOR, BRASS</b>  SIZE: <b>C</b> DWG. NO. <b>3530A-OL</b> REV <b>A</b> CREO      SCALE: NTS      SHEET 1 OF 1
	INCH	METRIC		DRAWN BY:	DATE:	
	X ± .1 .X ± .03 .XX ± .01 .XXX ± .005	X ± .8 .X ± .3 .XX ± .13		DL	12/18/20	
	63/	1.6/		CHECKED BY:	DATE:	
ANGLES ± 1/2°		WS	12/21/20	ENGINEER:	DATE:	
		WS	12/21/20	WS	12/21/20	

5

3

2

1