

4

3

2

1

MODEL NO.	MAX DELIVERY PRESSURE	DELIVERY PRESSURE GAUGE
3471A	15 PSI	0-30 PSI
3473A	50 PSI	0-60 PSI
3476A*	125 PSI	0-200 PSI
3478A*	200 PSI	0-400 PSI

*SUPPLIED WITH T-BAR HANDLE INSTEAD OF KNOB

DELIVERY PRESSURE GAUGE (SEE CHART)

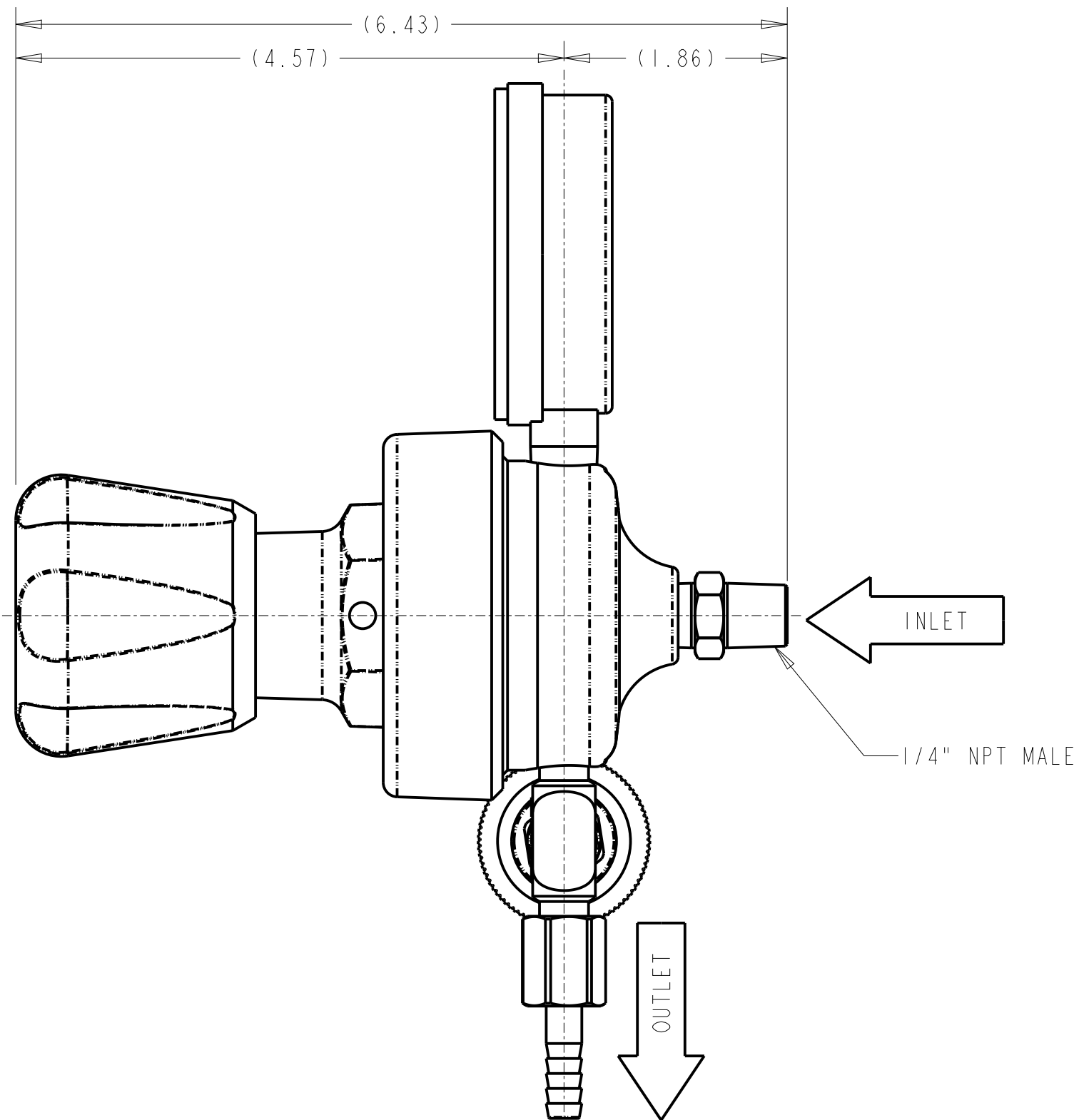
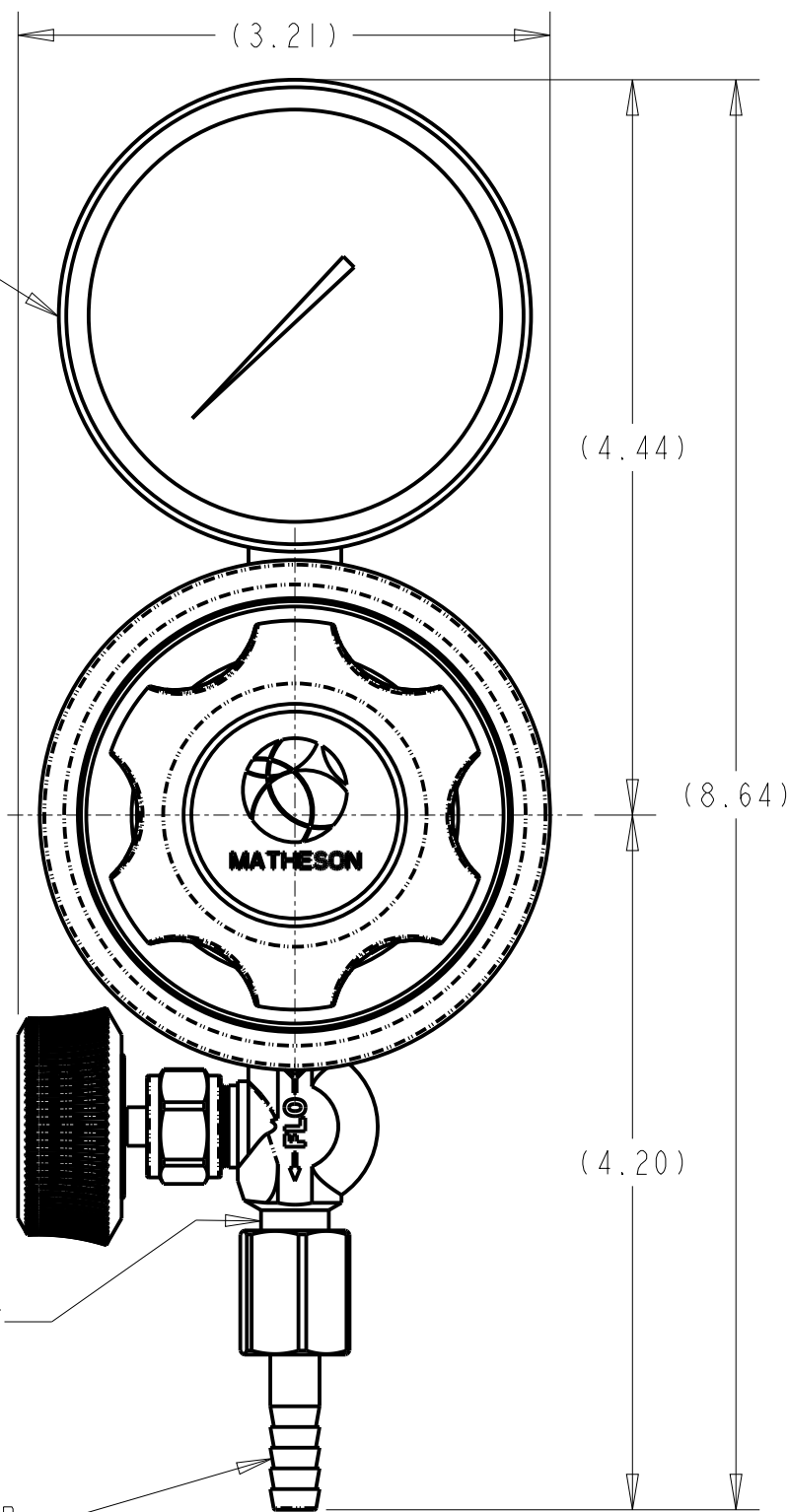
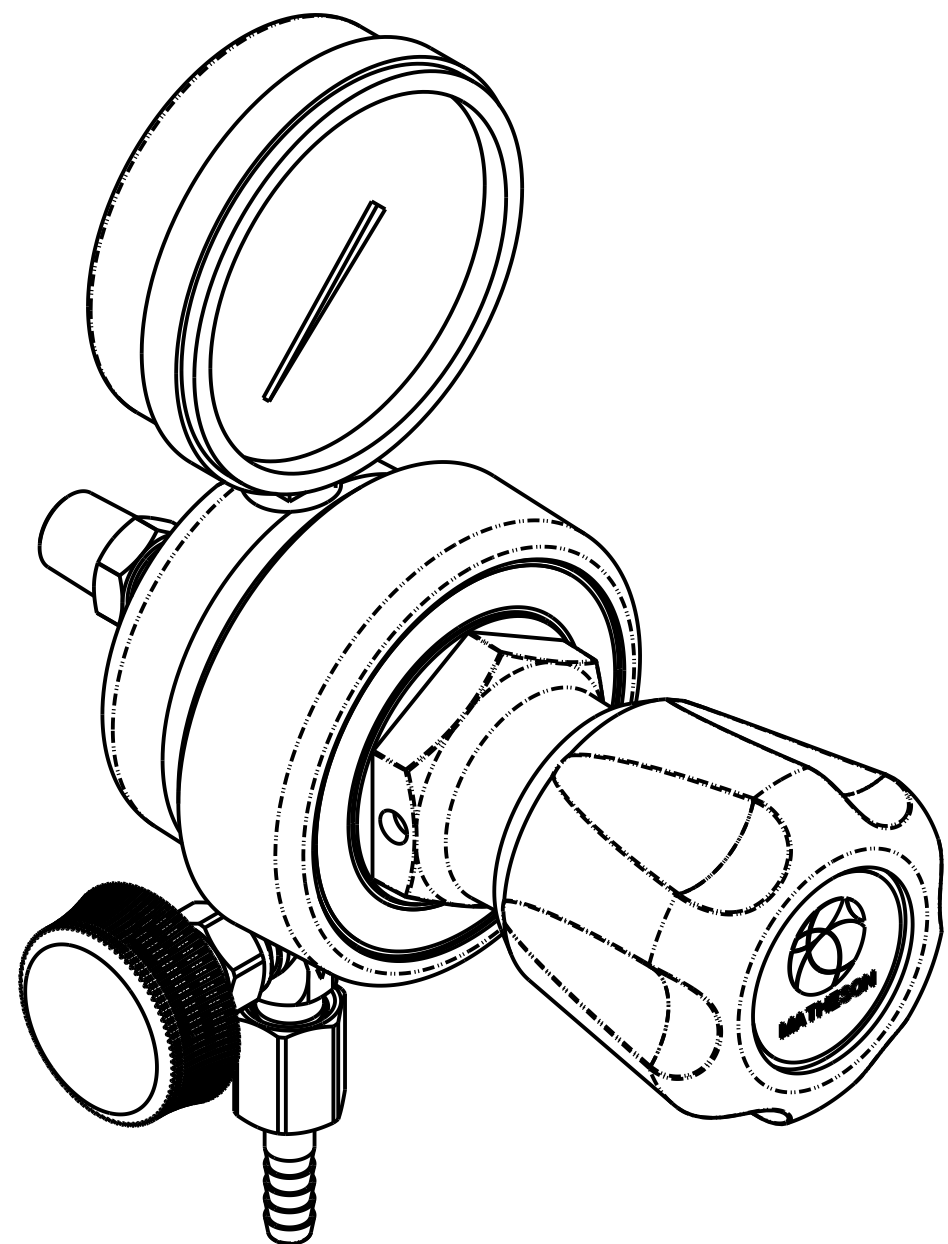

REF ONLY FOR PDM USE ONLY		DWG NO.	MODEL NO.
		3470A-OL-	M3322B-170-

REVISIONS					
SH-ZONE	REV	DESCRIPTION	ECO NO.	BY/DATE	APVD/DATE
B1	B	REVISED CLEANING SPECIFICATION	-	DL-4/6/23	WS-4/6/23
A5	C	ADDED TOP VIEW PORT LAYOUT	-	DL-4/24/23	WS-4/24/23

1/4" MNPT
1/4" HOSE BARB (SHIPPED LOOSE)

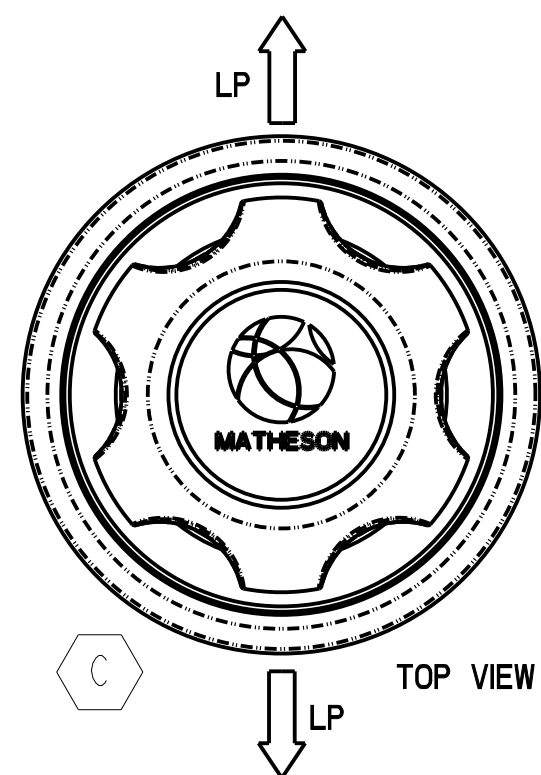

MATERIALS	
REGULATOR BODY	FORGED BRASS
REGULATOR BONNET	CHROME PLATED ZINC DIECAST
REGULATOR DIAPHRAGM	NEOPRENE
REGULATOR SEAT	NEOPRENE
REGULATOR SEALS	NEOPRENE
INLET FILTER	NICKEL PLATED BRONZE
GAUGE	CHROME PLATED BRASS
OUTLET VALVE BODY	FORGED BRASS
OUTLET VALVE PACKING	PTFE
OUTLET VALVE STEM	STAINLESS STEEL
OUTLET VALVE SEAT	BRASS

SPECIFICATIONS	
MAXIMUM INLET PRESSURE	350 PSI (2,415 kPa)
FLOW CAPACITY-REGULATOR (Cv)	0.53
FLOW CAPACITY-VALVE (Cv)	0.37
OPERATING TEMPERATURE	-20°F TO 140°F (-29°C TO 60°C)
PORTING (REGULATOR BODY)	1/4" NPT FEMALE
PORTING CONFIGURATION	1 HIGH, 2 LOW
INLET FILTER	10 MICRON - SINTERED
BONNET THREADING	N/A
CLEANING	CGA G 4.1
PRESSURE RATING	PER ANSI/ASME B31.3
TYP MAX FLOW (100 PSI DEL. PRESS.)	N/A
CONFORMS TO CGA E-4 STANDARD FOR GAS PRESSURE REGULATORS	

PROPRIETARY STATEMENT THIS DOCUMENT CONTAINS INFORMATION PROPRIETARY TO MATHESON TRI-GAS, INC. AND SHALL NOT BE REPRODUCED OR DISCLOSED TO THIRD PARTIES WITHOUT PRIOR WRITTEN CONSENT FROM MATHESON TRI-GAS.	TOLERANCES		MATERIAL:	APPROVALS		MATHESON ask...The Gas Professionals™ GAS EQUIPMENT TECHNOLOGY GROUP, MONTGOMERYVILLE, PA 18936		
	INCH	METRIC						
	X ± .1 .X ± .03 .XX ± .01 .XXX ± .005	X ± .8 .X ± .3 .XX ± .13 .XXX ± .005						
	63	1.6	THIRD ANGLE PROJECTION DO NOT SCALE DRAWING	DRAWN BY: DL DATE: 1/15/21 CHECKED BY: WS DATE: 1/21/21 ENGINEER: WS DATE: 1/21/21	TITLE: OUTLINE DRAWING 3470A SERIES, ECONOMY LINE REGULATOR	SIZE: C CREO	DWG. NO.: 3470A-OL	REV: C

5

3

2

1