

MODEL NO.	MAX DELIVERY PRESSURE	DELIVERY PRESSURE GAUGE
3200	50 PSI	0-100 PSI
3201	100 PSI	30" VAC-0-200 PSI
3203	150 PSI	30" VAC-0-300 PSI
3204	250 PSI	0-400 PSI

REF ONLY FOR PDM USE ONLY	DWG NO. 3200-CGA-OL-	MODEL NO. MREG-4400-XX-
---------------------------	----------------------	-------------------------

REVISIONS					
SH-ZONE	REV	DESCRIPTION	ECO NO.	BY/DATE	APVD/DATE
-	A	RELEASED FOR PRODUCTION	-	DL-1/26/20	WS-3/12/21

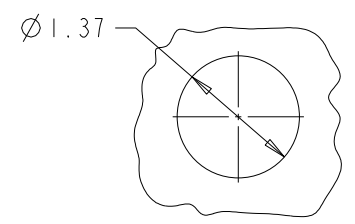

PANEL CUT-OUT

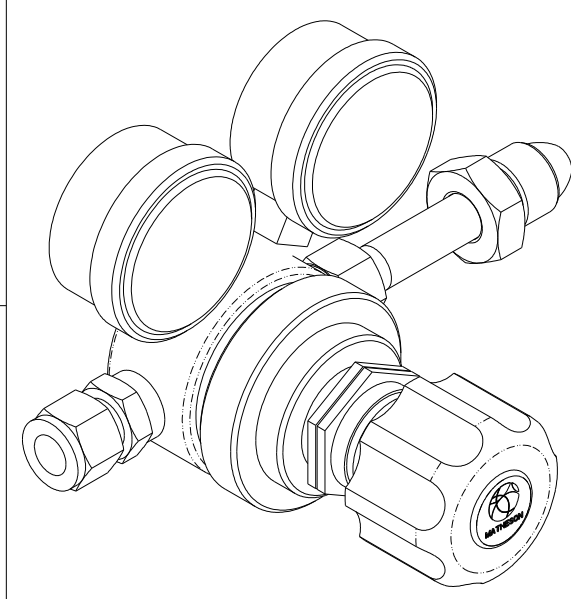
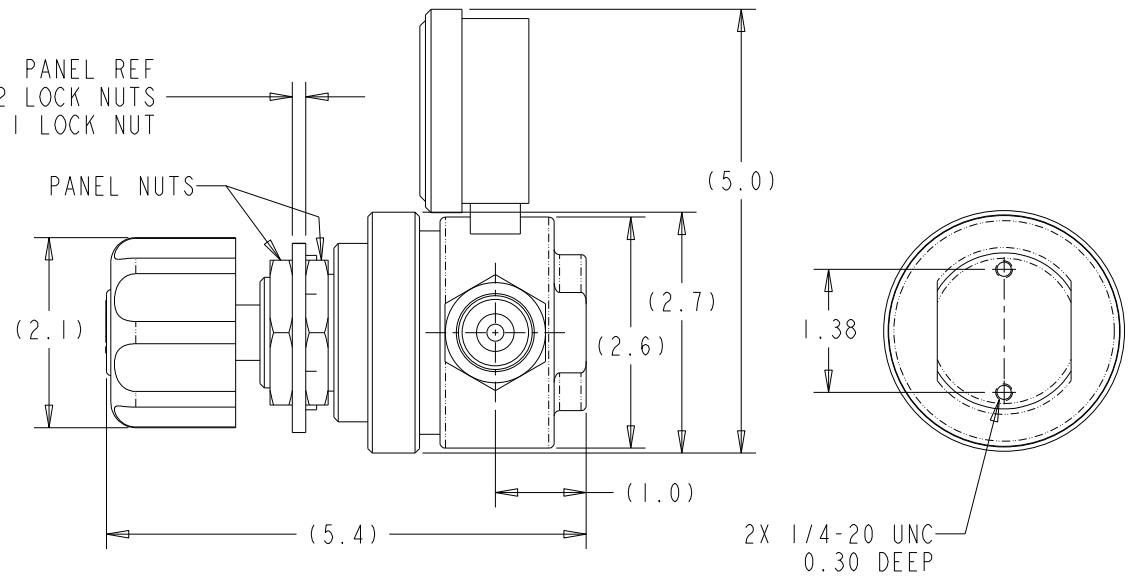
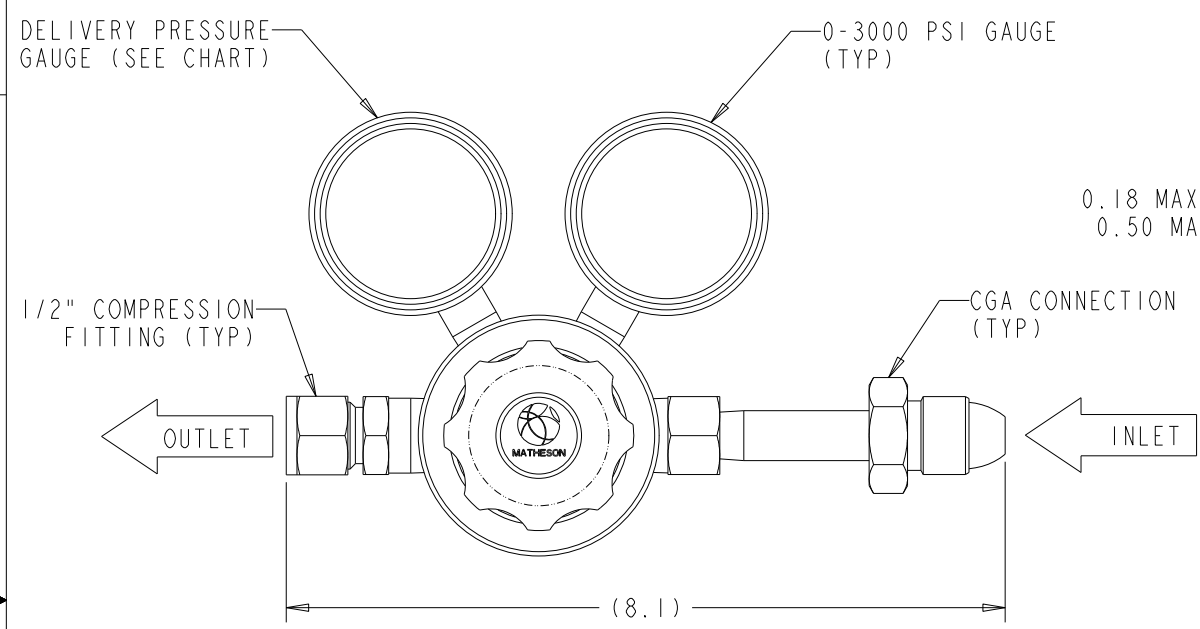

MATERIALS	
REGULATOR BODY	316 STAINLESS STEEL
REGULATOR BONNET	300 SERIES STAINLESS STEEL
REGULATOR DIAPHRAGM	316 STAINLESS STEEL
REGULATOR SEAT	PCTFE
REGULATOR SEAT RETAINER	NITRONIC 60
REGULATOR SEALS	PTFE

SPECIFICATIONS	
MAXIMUM INLET PRESSURE	3000 PSI (20,700 kPa)
FLOW CAPACITY-REGULATOR (Cv)	1.0
OPERATING TEMPERATURE	-40°F TO 140°F (-40°C TO 60°C)
PORTING (INLET/OUTLET)	1/2" NPT FEMALE
PORTING (GAUGES)	1/4" NPT FEMALE
PORTING CONFIGURATION	2 HIGH, 2 LOW
INLET FILTER	NONE
BONNET THREADING	1-5/16"-20
BONNET VENT HOLE	1/16" FNPT
LEAK TEST (INTERNAL)	BUBBLE-TIGHT
LEAK TEST (EXTERNAL)	1 X 10 <sup>-5</sup> SCCM-HE
CLEANING	CGA G 4.1 & ASTM G93 (INTER LEVEL)
PRESSURE RATING	PER ANSI/ASME B31.3
TYP MAX FLOW (100 PSI DEL. PRESS.)	30 SCFM-N2 (850 SLPM)

PROPRIETARY STATEMENT THIS DOCUMENT CONTAINS INFORMATION PROPRIETARY TO MATHESON TRI-GAS, INC. AND SHALL NOT BE REPRODUCED OR DISCLOSED TO THIRD PARTIES WITHOUT PRIOR WRITTEN CONSENT FROM MATHESON TRI-GAS.

TOLERANCES	
INCH	METRIC
X ± .1	X ± .8
.X ± .03	.X ± .3
.XX ± .01	.XX ± .13
.XXX ± .005	
63/	1.6/
ANGLES ± 1/2°	

MATERIAL:  
FINISH:  
THIRD ANGLE PROJECTION  
DO NOT SCALE DRAWING

APPROVALS	
DRAWN BY: DL	DATE: 1/26/21
CHECKED BY: WS	DATE: 3/12/21
ENGINEER: WS	DATE: 3/12/21

**MATHESON**  
ask. .The Gas Professionals™  
GAS EQUIPMENT TECHNOLOGY GROUP, MONTGOMERYVILLE, PA 18936

TITLE: **OUTLINE DRAWING 3200-CGA SERIES HIGH FLOW REGULATOR, SS BARSTOCK**

SIZE: C	DWG. NO. 3200-CGA-OL	REV: A
CREO	SCALE: NTS	SHEET 1 OF 1